

TECHNICAL DATA SHEET

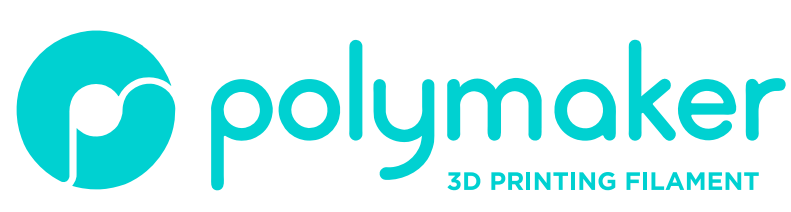

V5.6



PolyLite™ PLA Pro

PolyLite™ PLA Pro is a first of its kind combining high toughness and high rigidity, this professional PLA offers engineering properties with the ease of print of regular PLA.

WWW.POLYMAKER.COM

PHYSICAL PROPERTIES

PROPERTY	TESTING METHOD	TYPICAL VALUE
Density	ISO1183, GB/T 1033	1.23 g/cm ³ at 21.5°C
Melt index	210°C, 2.16 kg	15.5g/10min

MOISTURE ABSORPTION CURVE

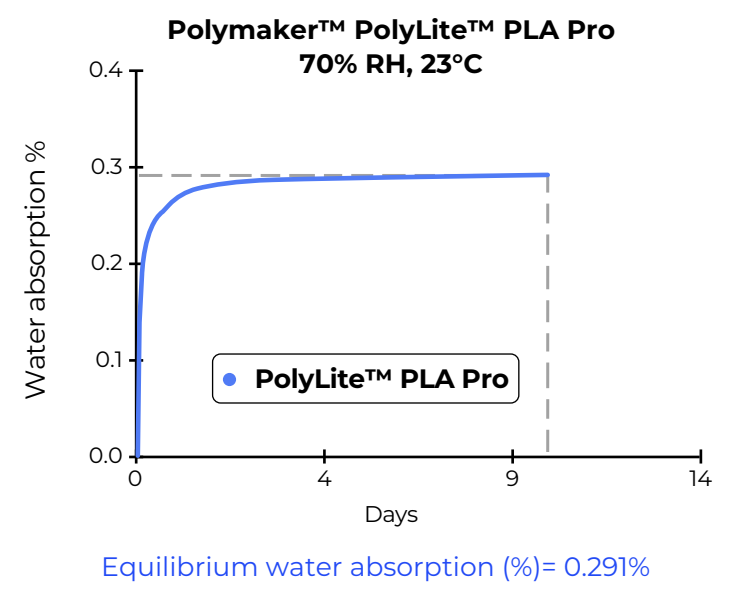

THERMAL PROPERTIES

PROPERTY	TESTING METHOD	TYPICAL VALUE
Glass transition temp.	DSC, 10°C/min	62°C
Melting temp.	DSC, 10°C/min	150°C
Crystallization temp.	DSC, 10°C/min	N/A
Decomposition temp.	TGA, 20°C/min	N/A
Vicat softening temp.	ISO 306, GB/T 1633	63°C
Heat deflection temp.	ISO 75 1.8MPa	58°C
Heat deflection temp.	ISO 75 0.45MPa	59°C

MECHANICAL PROPERTIES

PROPERTY	TESTING METHOD	TYPICAL VALUE
Young's modulus (X-Y)	ISO 527, GB/T 1040	2932.2 ± 55.3 MPa
Young's modulus (Z)		2633.0 ± 117.4 MPa
Tensile strength (X-Y)	ISO 527, GB/T 1040	49.8 ± 0.4 MPa
Tensile strength (Z)		36.5 ± 0.6 MPa
Elongation at break (X-Y)	ISO 527, GB/T 1040	6.3 ± 0.9 %
Elongation at break (Z)		2.4 ± 0.3 %
Bending modulus (X-Y)	ISO 527, GB/T 1040	2933.8 ± 78.3 MPa
Bending modulus (Z)		N/A
Bending strength (X-Y)	ISO 527, GB/T 1040	77.9 ± 0.4 MPa
Bending strength (Z)		N/A
Notched charpy impact strength (X-Y)	ISO 179, GB/T 1043	17.1 ± 1.2 kJ/m ²
Notched charpy impact strength (Z)		N/A

CHEMICAL RESISTANCE DATA

PROPERTY	TYPICAL VALUE
Effect of weak acids	Good
Effect of strong acids	Poor
Effect of weak alkalis	Fair
Effect of strong alkalis	Poor
Effect of oils and grease	Good

Good:
Material may get minor attack after long periods of storage with chemical at ambient temperature

Fair:
Material can be used for short time contact with chemicals at ambient temperature

Poor:
Material becomes unstable on contact with chemical at ambient temperature

RECOMMENDED PRINTING CONDITIONS

Nozzle temperature	190-230°C
Build plate temperature	30-60°C
Build surface treatment	PC and Textured PEI
Cooling fan	ON
Closure chamber	Not needed

Printing Speed	50-200mm/s
Drying temp. and time	55°C/6H
Retraction distance	1-3 (mm)
Retraction Speed	20-40 (mm/s)

*Based on 0.4mm nozzle. Printing conditions may vary with different nozzle diameters.



**PolySupport™
PolyDissolve™ S1**
Recommended support material



PolyBox™ or PolyDryer™ Box
Recommended storage for excellent printing quality

HOW TO MAKE SPECIMENS

Printing temperature	230°C
Bed temperature	50°C
Top & bottom layer	3
Environmental Temperature	Ambient temp.

Infill	100%
Shell	2
Cooling fan	ON

FLEXURAL TESTING SPECIMEN ISO 178, GB/T 9341

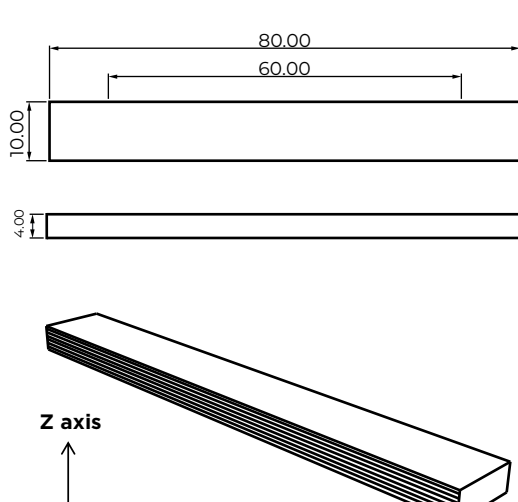

TENSILE TESTING SPECIMEN ISO 527, GB/T 1040

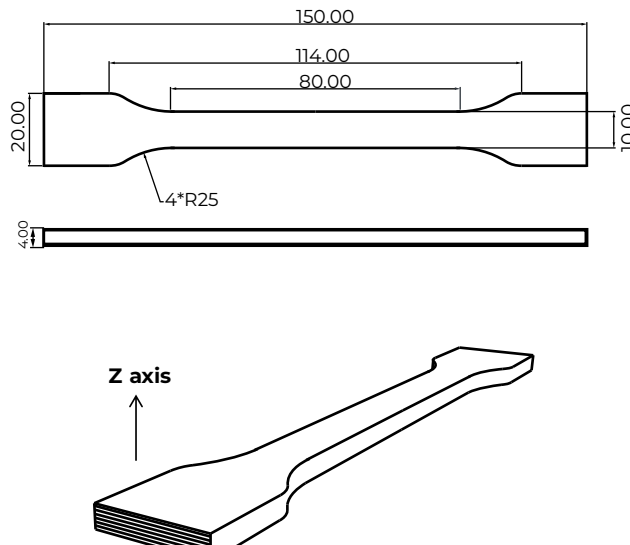

IMPACT TESTING SPECIMEN ISO 179, GB/T 1043

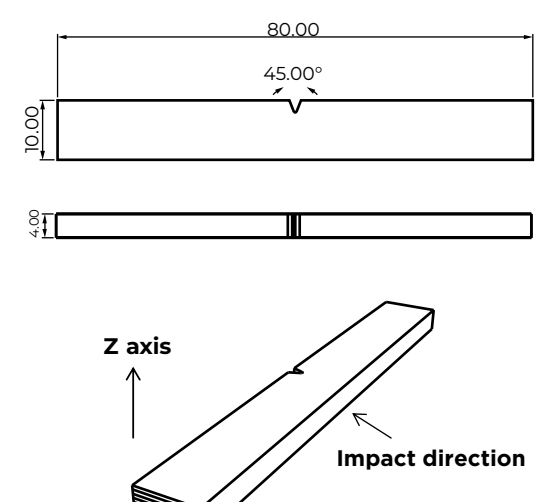

*Based on testing with Polymaker™ PolyLite™ PLA Pro (SKU: PA07057)

DISCLAIMER

The typical values presented in this data sheet are intended for reference and comparison purposes only. They should not be used for design specifications or quality control purposes. Actual values may vary significantly with printing conditions. End-use performance of printed parts depends not only on materials, but also on part design, environmental conditions, printing conditions, etc. Product specifications are subject to change without notice. Each user is responsible for determining the safety, lawfulness, technical suitability, and disposal/recycling practices of Polymaker™ materials for the intended application. Polymaker™ makes no warranty of any kind, unless announced separately, to the fitness for any use or application. Polymaker™ shall not be made liable for any damage, injury or loss induced from the use of Polymaker™ materials in any application.